

7 Piece Heavy Duty Coilspring Compressor
Left Hand Version



Information

- For use on all left handed coil springs fitted on all modern vehicles.
- To be used on McPherson struts with cylindrical and conical springs.
- Applications: Audi, Alfa Romeo, BMW, Chrysler, Citroën, Ford, Fiat, Honda, Hyundai, Kia, Land Rover, Mazda, Mitsubishi, Nissan, Opel, Peugeot, Porsche, Renault, Saab, Seat, Subaru, Suzuki, Toyota, Vauxhall, VW and Volvo.
- Contains:

1 x telescopic spindle
3 x chuck couples

1 x spacer for conical springs
6 x plastic spring protectors

Precautions

Always wear safety gear.
Working in a clean and safe environment.
This task should be carried out by trained personnel.
Make sure to consult manufacturers manual.
Do NOT use with air tools.

Contents

- 1 Main Body
- 1 Extended Bracket
- 3 Parts Jaws

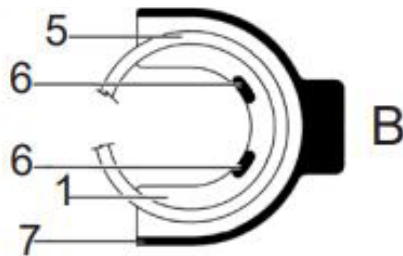
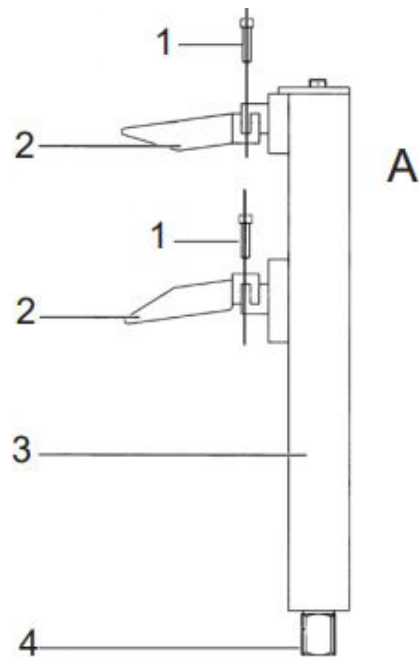

	Description
1	Retaining Bolts
2	Yoke
3	Compressor Body
4	Hex Nut
5	Spring
6	Safety Lips
7	Outer Rib

Information

WARNING: Do NOT use the impact driver.
 - Maximum load: 9800 N.

1 Pair x 1.6 Kg Use Range: 80-115mm

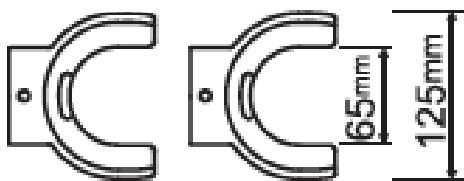

1 Pair x 2.5 Kg Use Range: 110-150mm

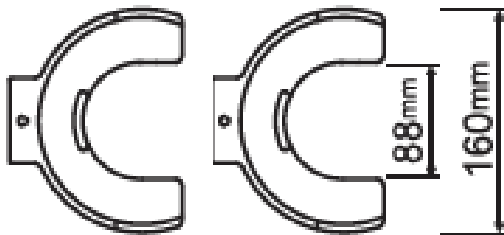

5.17 Kg

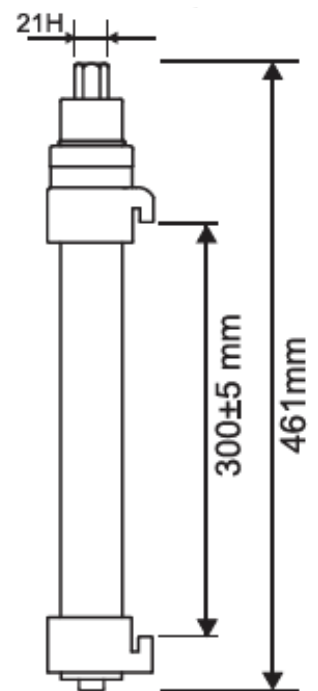

1 Pair x 2.6 Kg Use Range: 140-195mm

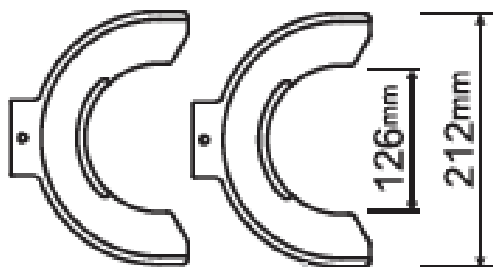

0.6 Kg

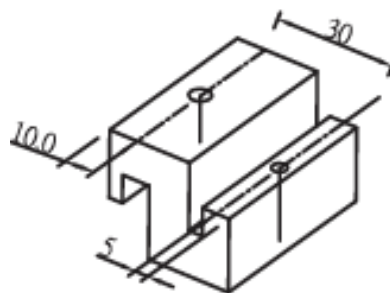

Instructions

WARNING: Do NOT compress the spring too much so that the coil windings touch (Fig. 1A) or so the jaws touch (Fig. 1B).

- The jaws and the body of the compressor must be correctly aligned at all times during spring compression (Fig. 2A).
- For conical springs the centre line of the spring must remain parallel to the compressor body (Fig. 2B).
- Use the extension block if necessary (Fig.3) in order to keep the spring and compressor body parallel.
- Secure the strut using a clamp, vice, or other appropriate holding device.

Step 1

- Mount the selected jaws on the compressor body. Fit the retaining bolts and tighten securely.

Step 2

- Rotate the hexagonal nut. Use an air or hand tool to drive the jaws apart to the length of the spring; allowing the compression of as many windings as possible.

Step 3

- Place the spring strut compressor onto the spring and make sure the spring sits correctly between the safety lips (6) and the outer rib (7) so that it cannot slide out during compression.
- Ensure the jaws and body are aligned correctly. (Fig.2 and 3).

Step 4

- Rotate the hexagonal nut. Use an air or hand tool. Compress the spring until the upper support bearing is free. The spring will rotate.

- To decompress, reverse the compress procedure.

Before Each Use:

- Check the compressor and make sure it is not damaged or worn.
- Grease the compressor spindle at least every six months.
- Make sure the compressor is clean.
- Store in a safe and dry place.

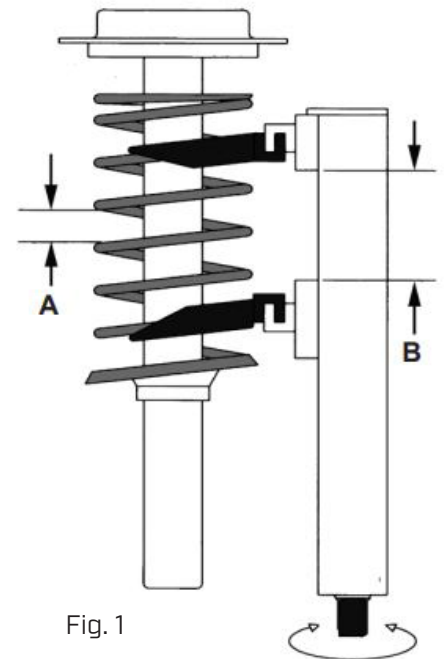

Fig. 1

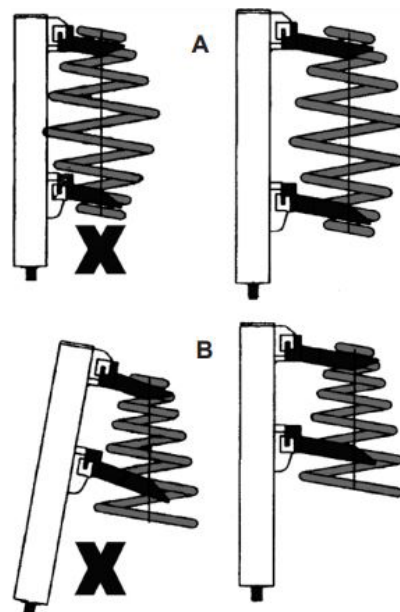

Fig. 2

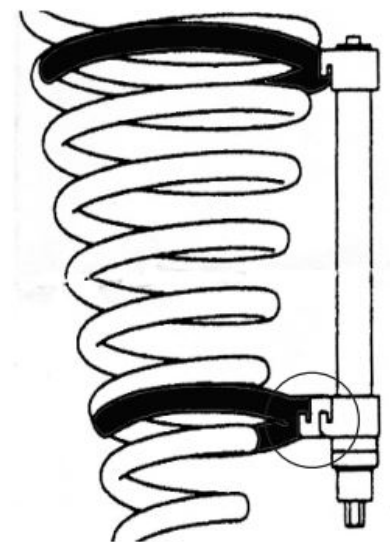

Fig. 3

Warranty

If you are unsure on how to use the item please contact us. If it were to fail due to a manufacturing fault or poor workmanship we will repair or replace it. Please contact your local dealer in the event you need to send the item back. You can also make a repair/replacement request on our website and download & complete the form online. Normal wear and tear along with misuse will void any warranty. Consumables are not covered under warranty.

www.welzh.com

Limited **12 month** warranty



Welzh Werkzeug Ltd.
Loanwath Road
Gretna, Scotland
DG16 5HD
+44 (0)1461 700120